

Contact
E-mail
Phone

Customer

Contact
E-mail
Phone

Technical data

High-pressure multistage centrifugal pump
Helix FIRST V 1008-5/16/E/S/400

Project name

Project ID
Installation location
Customer pos.no

Date 06.09.2018

Duty chart

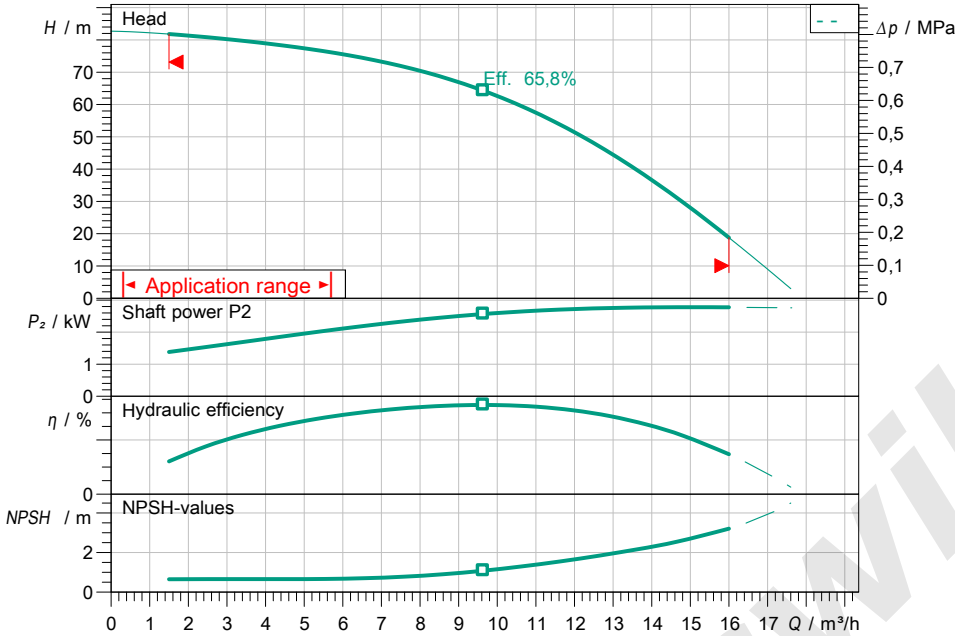

pump curves in accordance with ISO 9906, Appendix A

Dimensions

H	899
H2	607
Ø M	217
X	141

mm

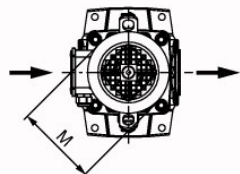
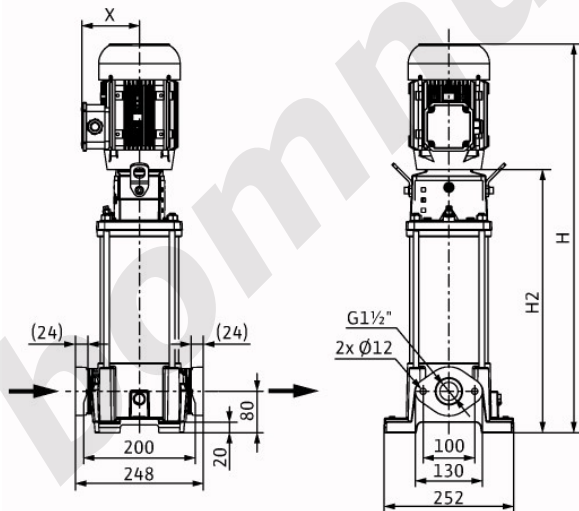
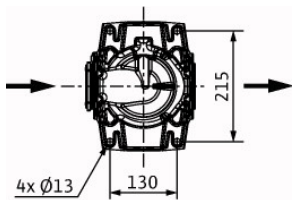

Requested data

Flow	
Head	
Media	Water 100 %
Fluid temperature	20,00 °C
Density	998,30 kg/m³
Kin. viscosity	1,00 mm²/s

Hydraulic data (Duty point)

Flow	
Head	
Shaft power P2	
Hydraulic efficiency	
NPSH	

Product data

High-pressure multistage centrifugal pump	
Helix FIRST V 1008-5/16/E/S/400-50	
Max. operating pressure	1,6 MPa
Inlet pressure max.	10 bar
Fluid temperature	-30 °C ... +120 °C
Max. ambient temperature	40 °C
Minimum Efficiency Index (MEI)	≥ 0.70

Motordata per Motor/Pump

Motor efficiency level	IE3
Mains connection	3~ 400 V / 50 Hz
Permitted voltage tolerance	±10 %
Max. speed	2900 1/min
Rated power P2	3,00 kW
Rated current	5,50 A
Power factor	0,89
Efficiency	50% / 75% / 100%
	85,6/87/87,1%
Degree of protection	IP 55
Insulation class	F
Motor protection	n0

Fitting dimensions

Pipe connection on the suction side	G 1 1/2, PN 16
Pipe connection on the pressure side	G 1 1/2, PN 16

Materials

pump housing	EN-GJL-250 (cataphoretic-coated)
Impeller	1.4307 [AISI304L]
Static seal	EPDM
pump shaft	1.4301 [AISI304]
Mechanical seal	Q1BE3GG

Information for order placements

Weight approx.	48 kg
Item number	4200954